

# Sliding Patio Doors

Our investment in security secures your investment

01404 41999 01404 43175

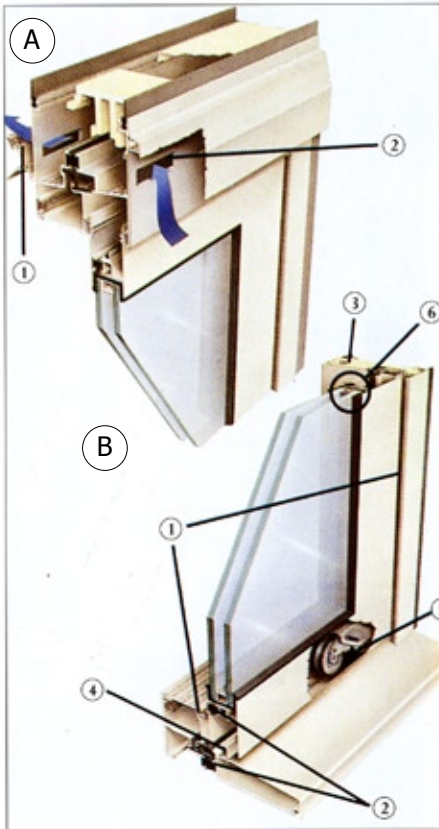

(A) Cut-away of the top of a patio panel and frame, showing (1) the controllable hidden night ventilator, with (2) insect and fly screen.

(B) Cut-away of the bottom of a sliding patio door panel showing (1) the high performance weatherseals, (2) thermal barriers, (3) foam insulation, (4) stainless steel track, (5) tandem rollers for smooth trouble free operation, and (6) glass built into the panel for increased security.

(C) Cut-away of the Monalock® Security Locking System showing the optional centre hook lock (1), which secures the door to the frame, and security key cylinder with anti-drill inserts (2) available when the shoot head bolt option is specified. (3) The heads of the 4 locking bolts locate behind heavy gauge stainless steel keeps to prevent the door being forced from the frame.

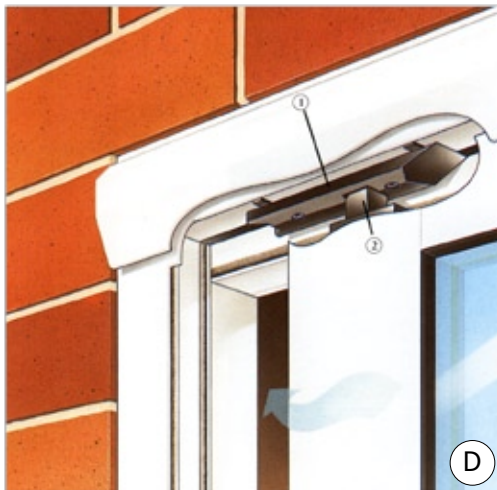
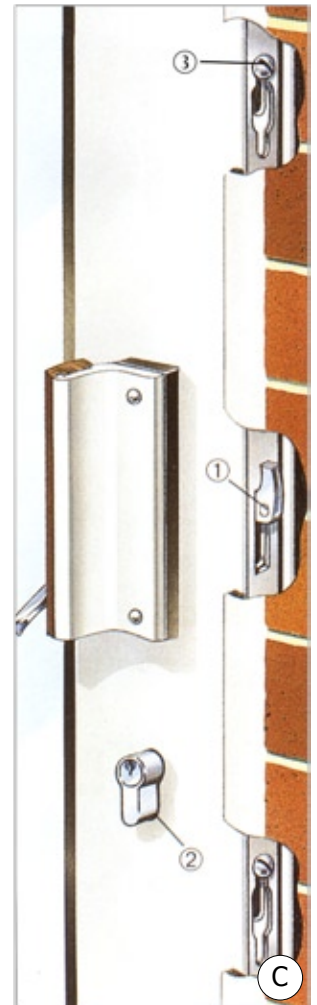

(D) All sliding patio door frame heads are fitted with (1) anti-lift blocks to prevent the door panels being lifted out of the frame, and (2) optional shoot bolts which allow the door to be held partially open for the flow of fresh air but stops toddlers or pets getting out. Our 'anti-slam' feature avoids damage to the locking mechanism should the door be slammed closed.



(E) When closed, the sliding panel (1) interlocks with the fixed panel to prevent them being levered apart.

